

N°	Modifica	Data	Firma

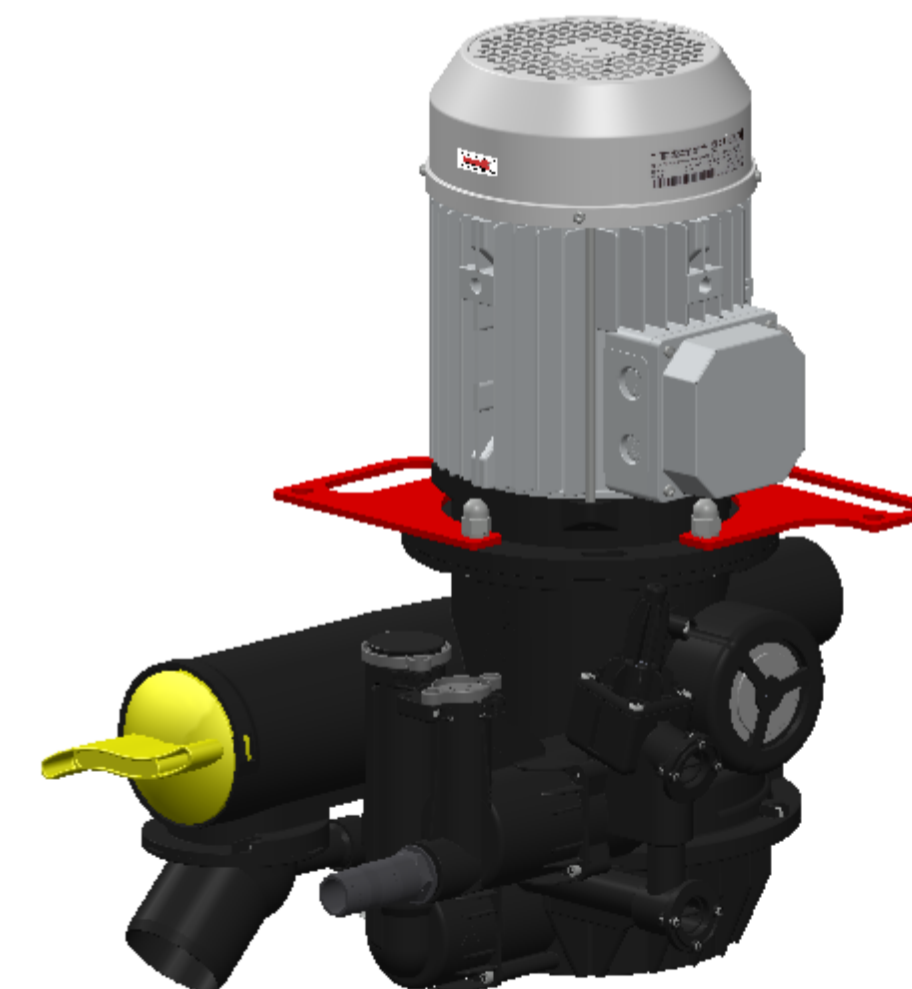
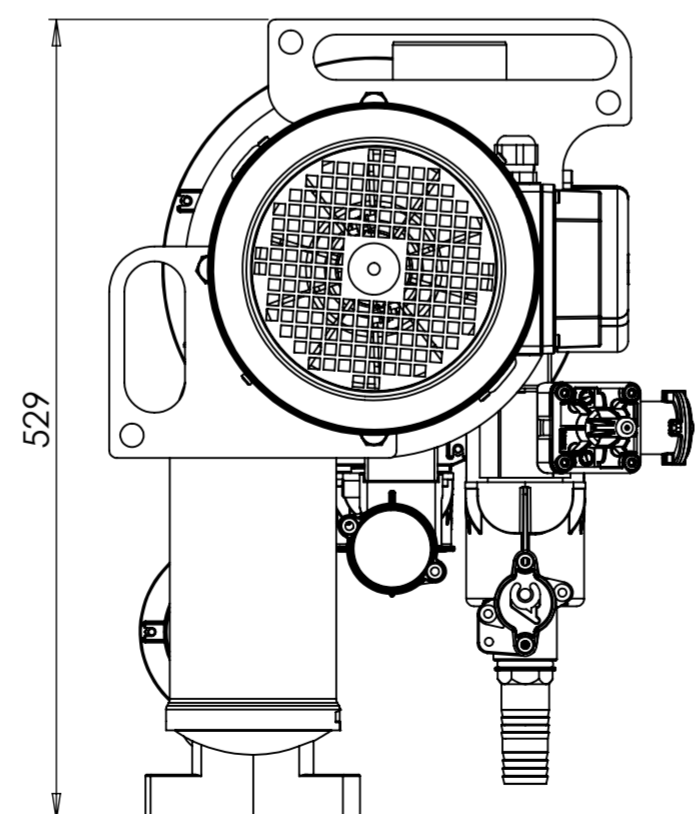
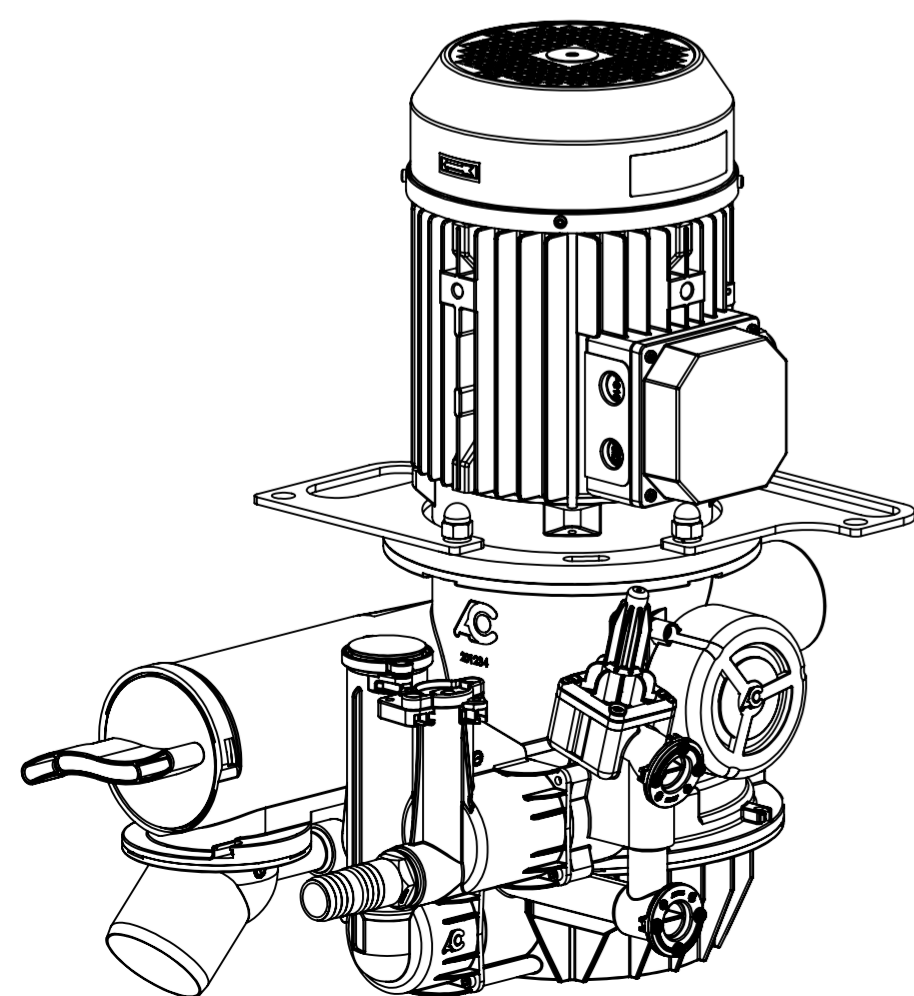
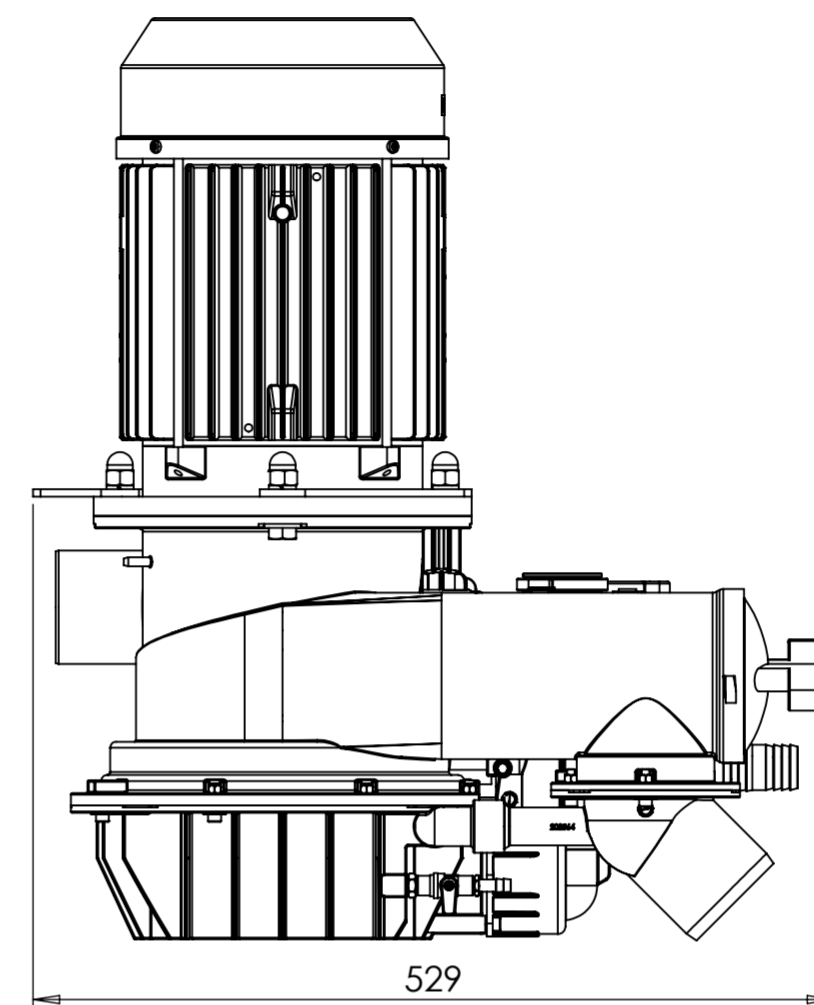
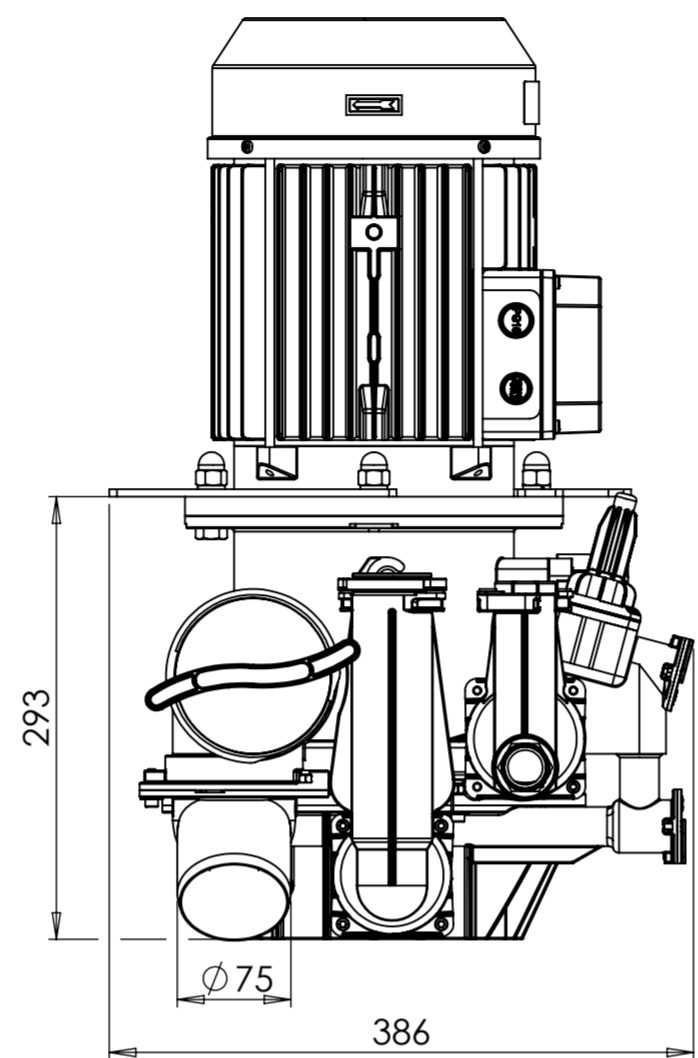
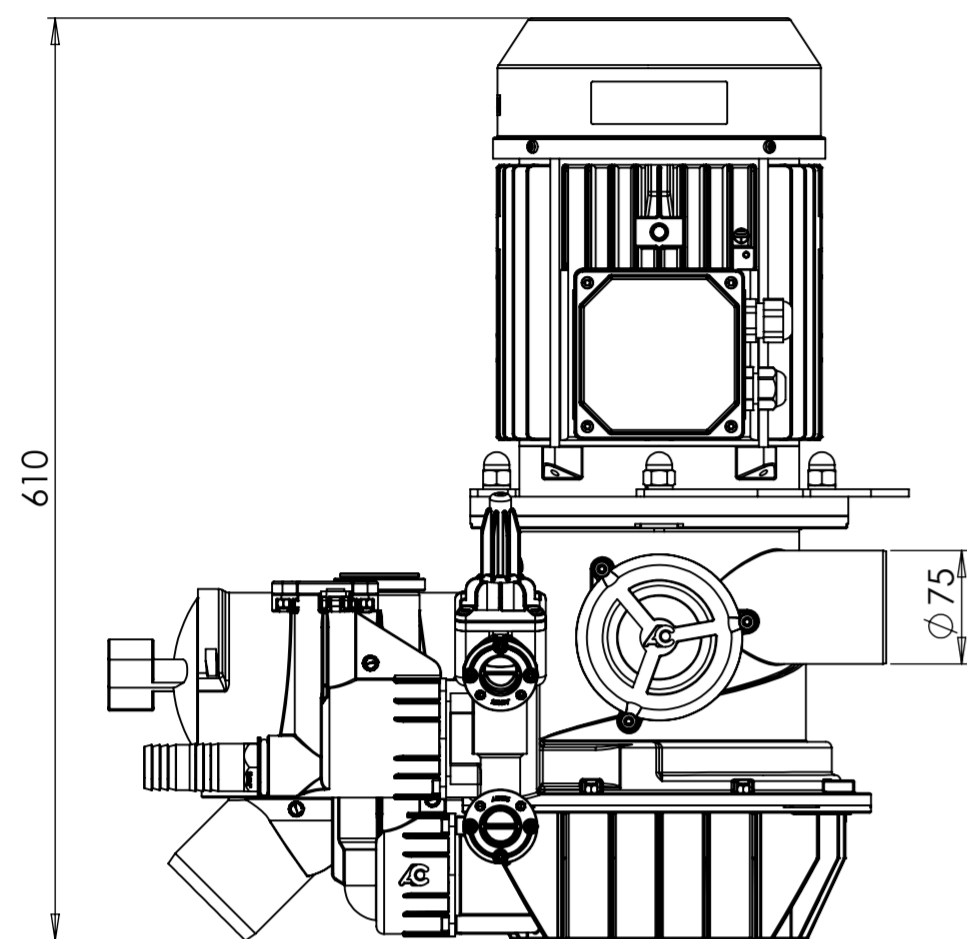

POS.	CODICE	MATERIALE GREZZO - DESCRIZIONE COMPONENTI	Q.TA'	DISEGNO NUMERO	
	DISEGNATO	APPROVATO		Peso-Kg	Modello
DATA	18/07/2016	18/07/2016		0.0	0
FIRMA	MORTALI			SCALA	
				1:5	
 Cattani S.p.A. Via Natta 6/A 43122 Parma - Italy T. +39 0521 607 604 F. +39 0521 607 628 info@cattani.it www.cattani.it			ESEGUIRE LE QUOTE SENZA INDICAZIONE IN CLASSE DI TOLLERANZA FINE SECONDO UNI ISO 2768 DEL 1991 (FORI TOLLERANZA +/- ALBERI TOLLERANZA -) GOLE DI SCARICO PER PARTI DA RETTIFICA SECONDO UNI4386 FORME E/F		
DENOMINAZIONE			CODICE		
SEPAR.CENTRIF.MAXI-SMART No IDROCICL.			025409		
GRUPPO MACCHINA		DISEGNO NUMERO			
MAXI-SMART		CF10-01-50			