

N°	Modifica	Data	Firma
01	MODIFICA DELLA CASSA CENTRALINO	04/07/2016	MORTALI

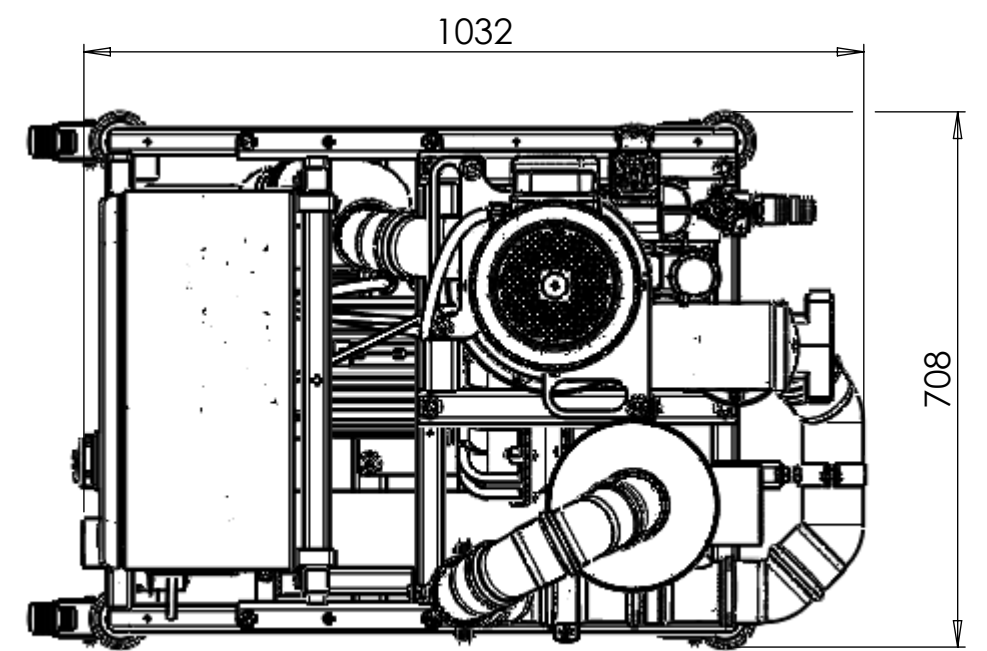
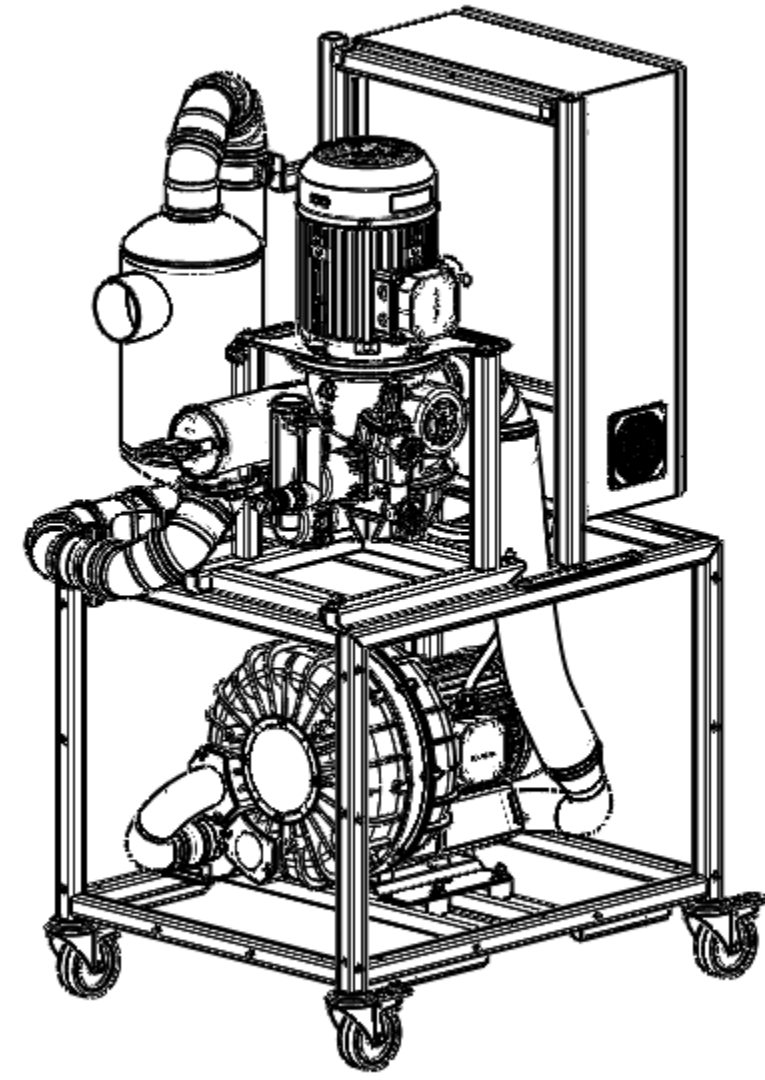
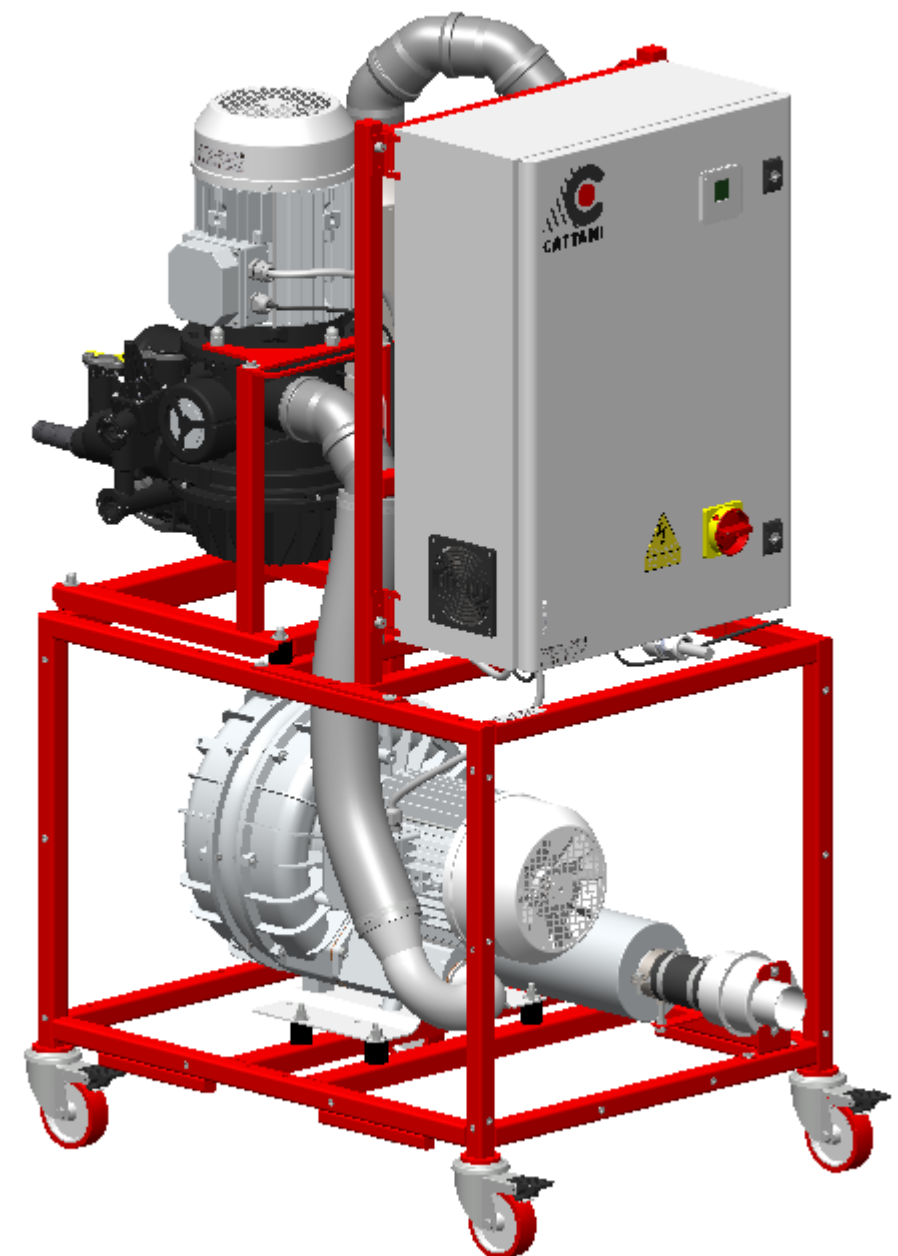
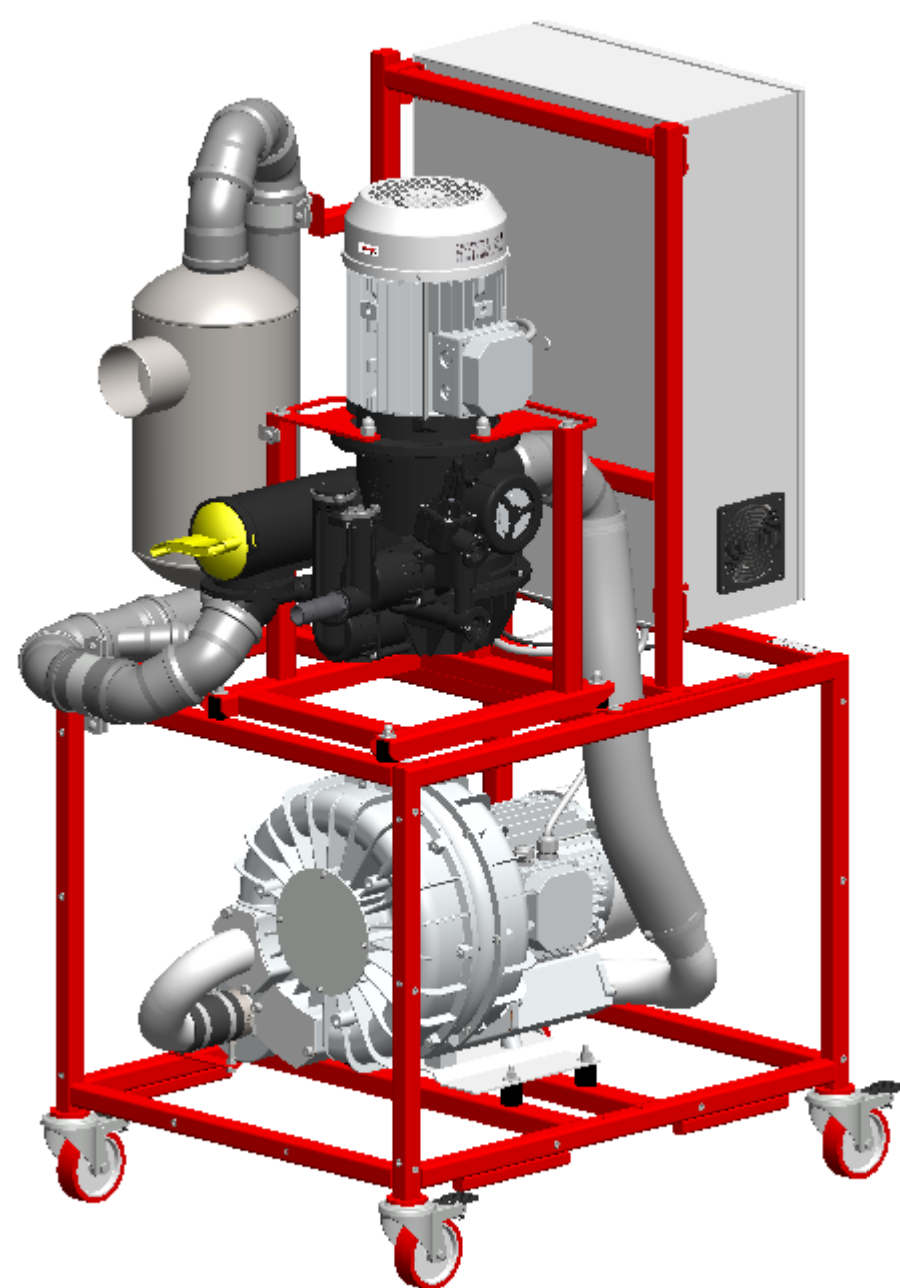
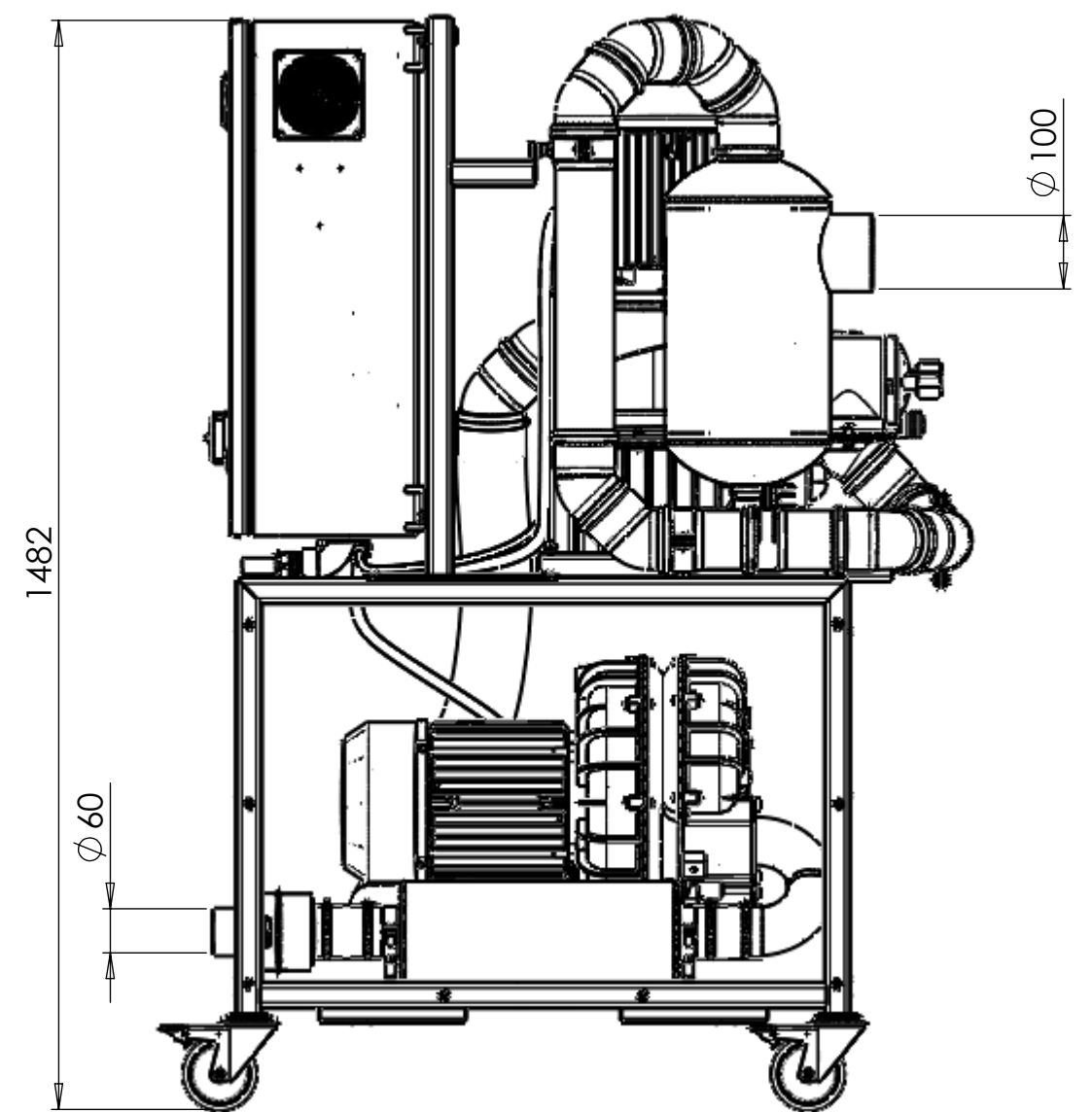
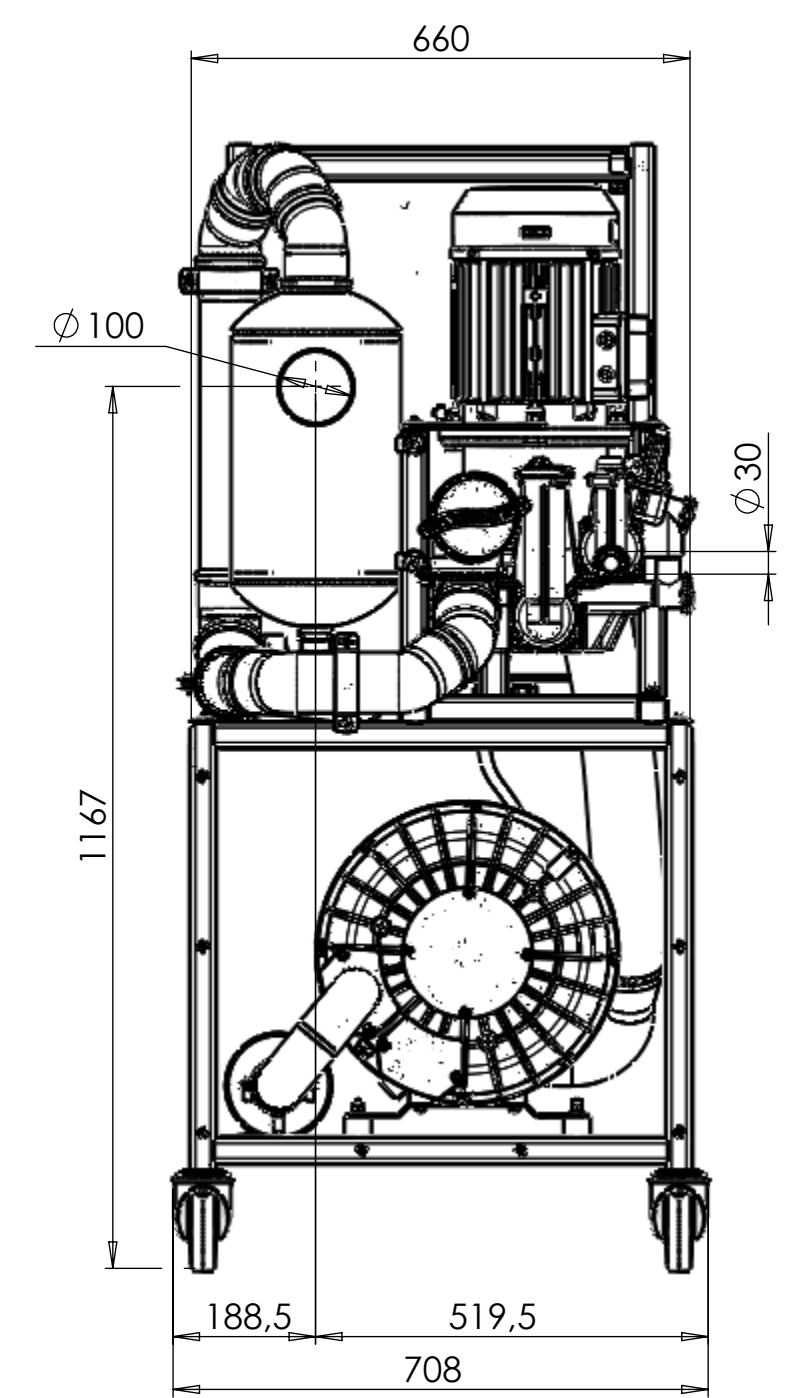
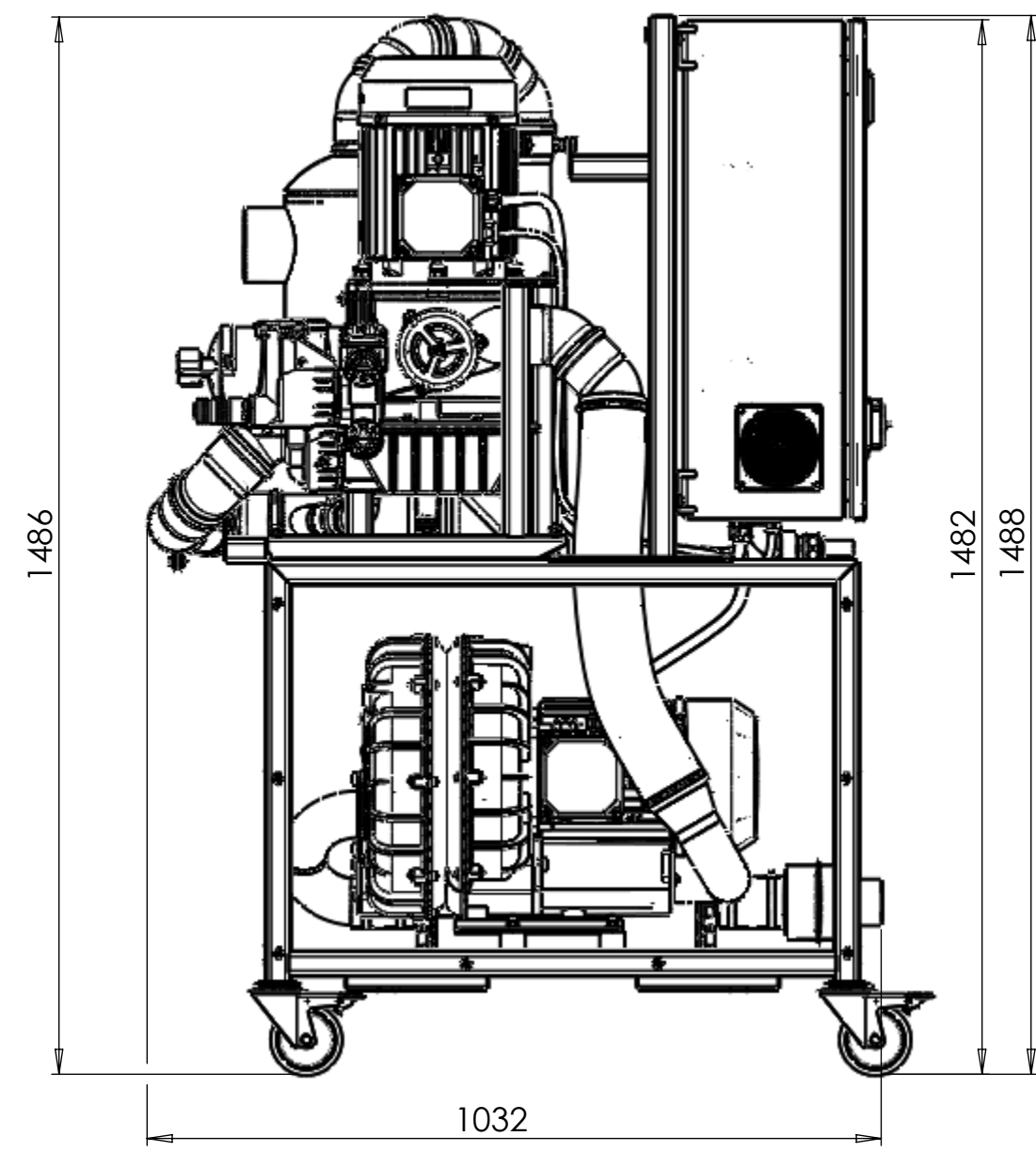
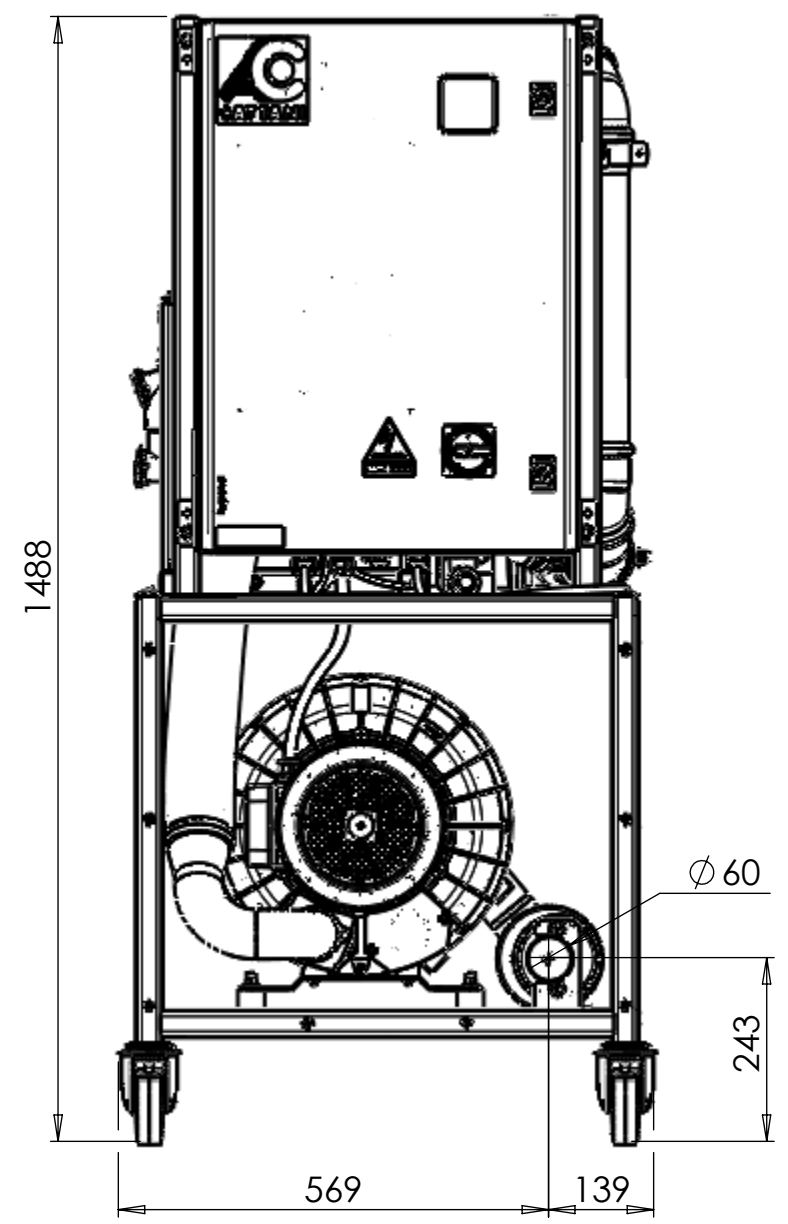

POS.	CODICE	MATERIALE GREZZO - DESCRIZIONE COMPONENTI	Q.TA'	DISEGNO NUMERO	
	DISEGNATO	APPROVATO		Peso-Kg	Modello
DATA	04/07/2016	04/07/2016		219.0	0
FIRMA	MORTALI			SCALA 1:10	
Cattani S.p.A. Via Natta 6/A 43122 Parma - Italy T. +39 0521 607 604 F. +39 0521 607 628 info@cattani.it www.cattani.it				ESEGUIRE LE QUOTE SENZA INDICAZIONE IN CLASSE DI TOLLERANZA FINE SECONDO UNI ISO 2768 DEL 1991 (FORI TOLLERANZA +/- ALBERI TOLLERANZA -) GOLE DI SCARICO PER PARTI DA RETTIFICA SECONDO UNI4386 FORME E/F	
DENOMINAZIONE				CODICE	
MAXI "SMART" SCARENATO				035200	
GRUPPO MACCHINA				DISEGNO NUMERO	
MAXI-SMART				CF10-05-00	