

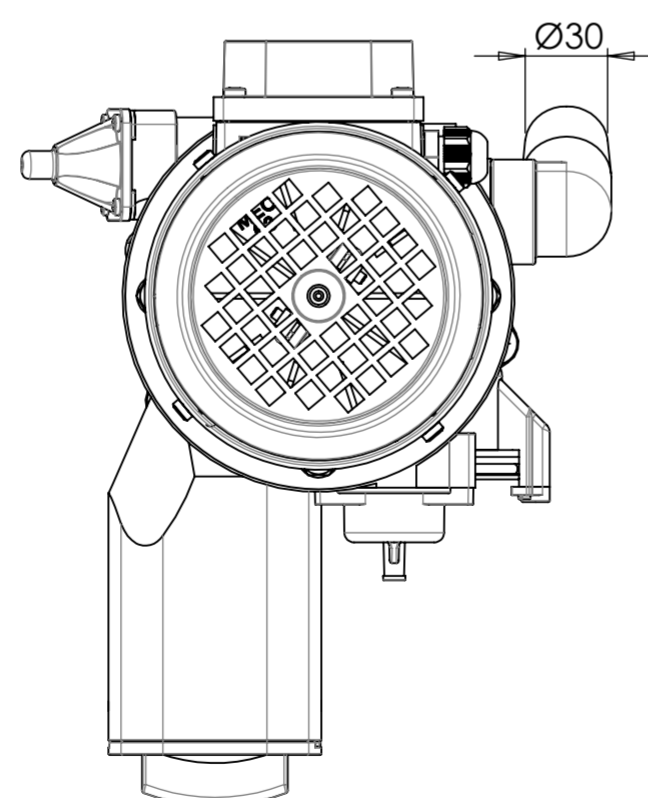

N°	Modifica	Data	Firma

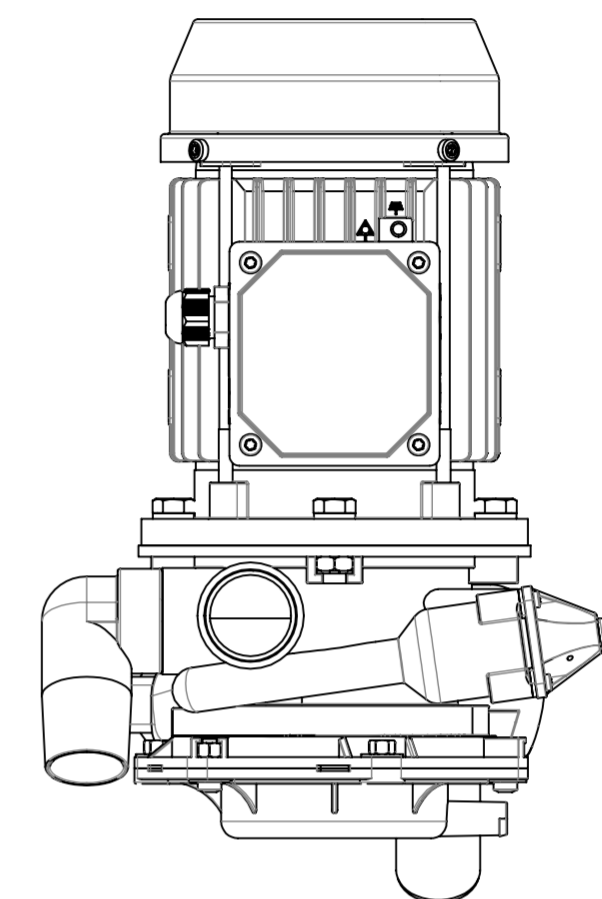
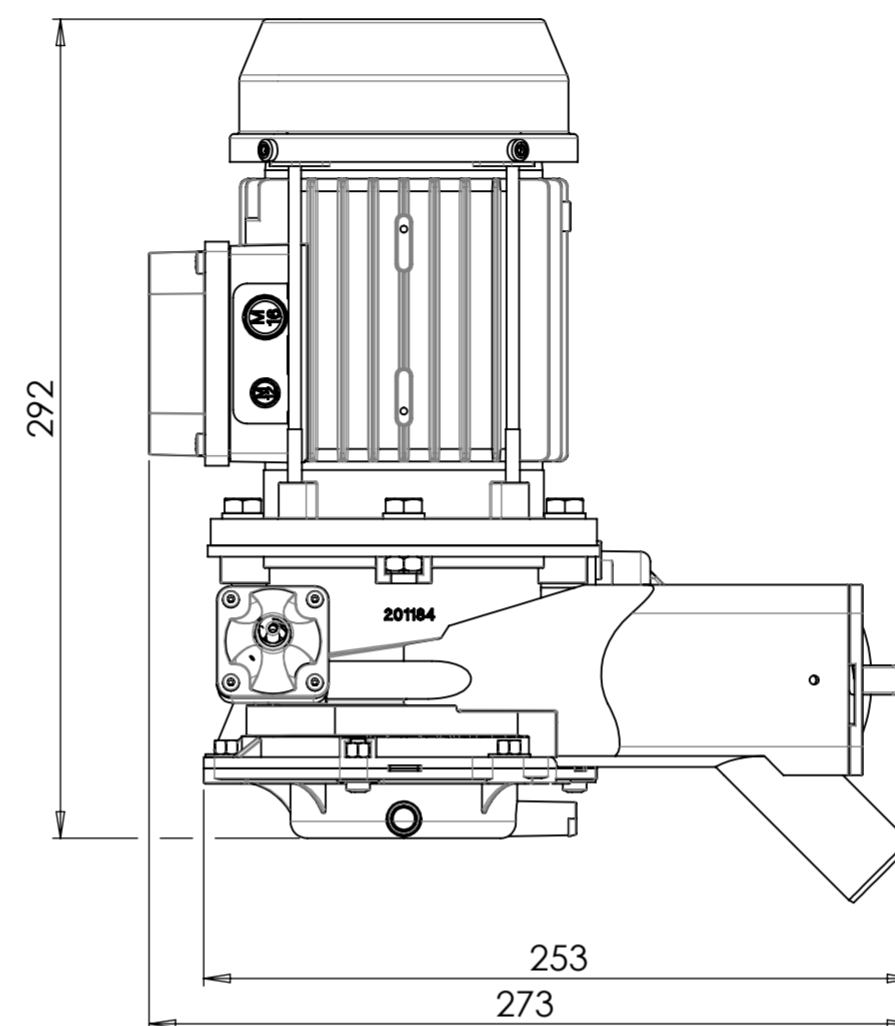
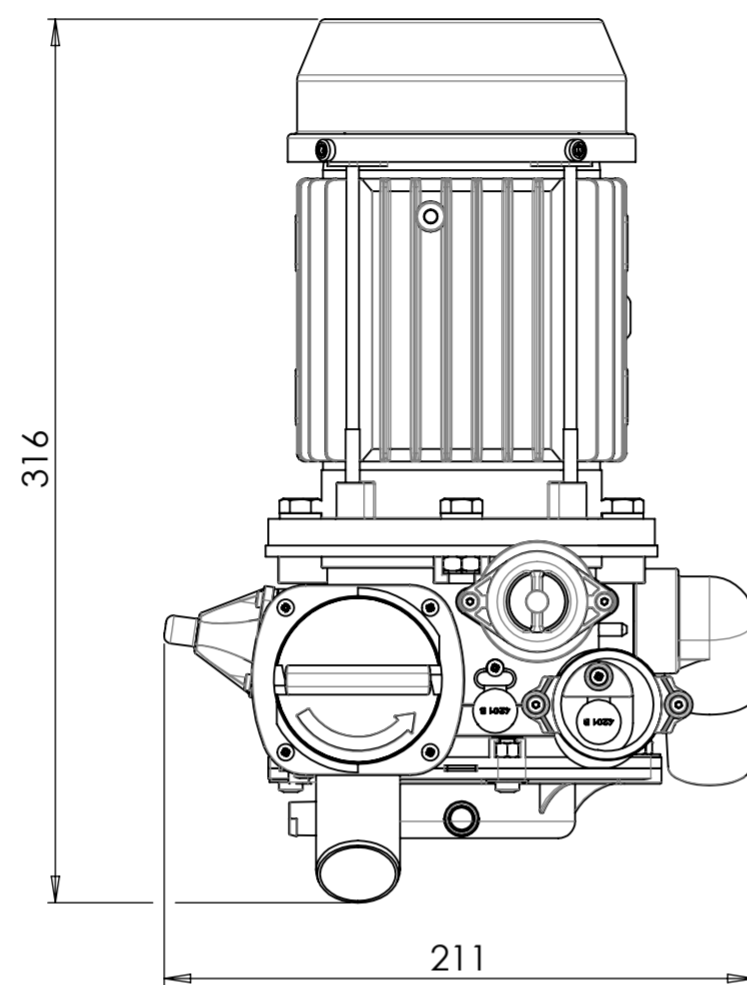
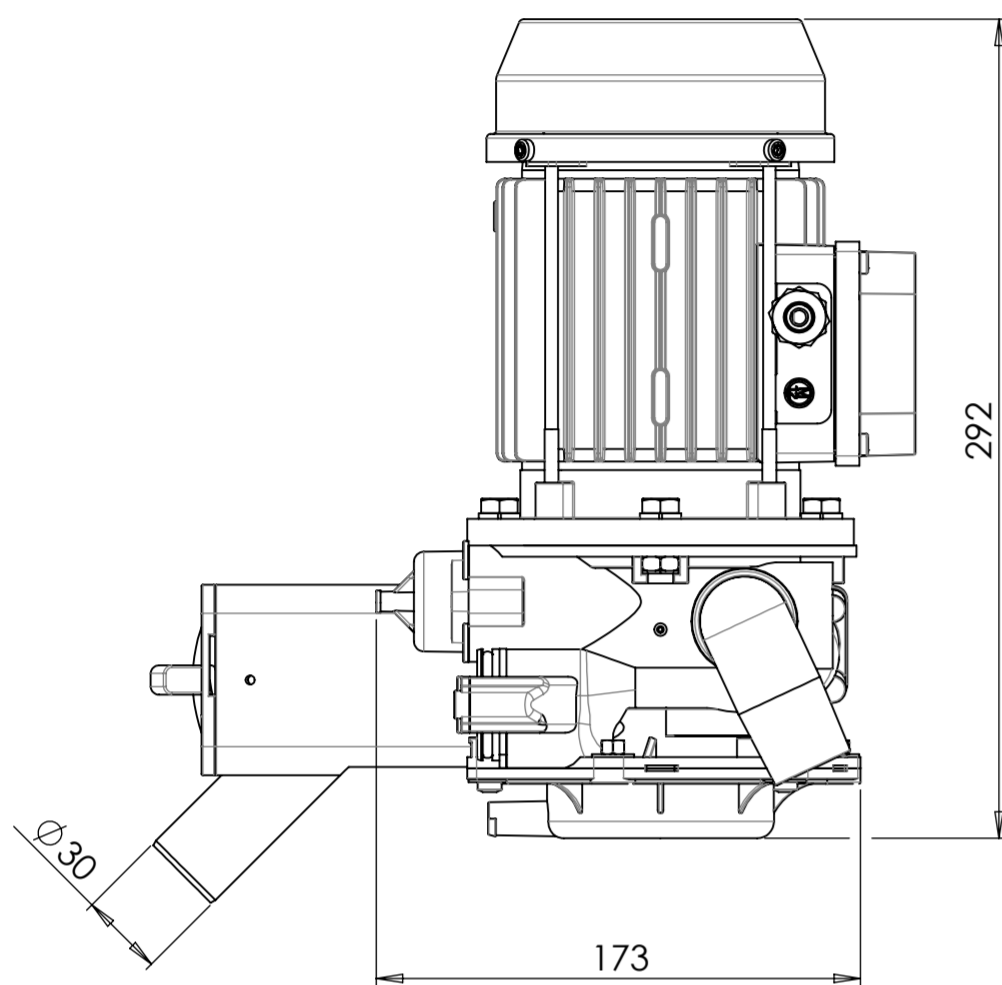

POS.	CODICE	0	MATERIALE GREZZO - DESCRIZIONE COMPONENTI	Q.TA'	DISEGNO NUMERO
DATA	DISEGNATO	APPROVATO	Treatments termici e/o superficiali	Peso-Kg	Modello
FIRMA	MORTALI		0	10.0	0
 <p>Cattani S.p.A. Via Natta 6/A 43122 Parma - Italy T. +39 0521 607 604 F. +39 0521 607 628 info@cattani.it www.cattani.it</p>			<p>ESEGUIRE LE QUOTE SENZA INDICAZIONE IN CLASSE DI TOLLERANZA <b>FINE</b> SECONDO UNI ISO 2768 DEL 1991 (FORI TOLLERANZA +/- ALBERI TOLLERANZA -) GOLE DI SCARICO PER PARTI DA RETTIFICA SECONDO UNI4386 FORME E/F</p>		<p>SCALA 1:2.7</p>
<p>DENOMINAZIONE</p> <p>SEPAR.CENTR.COMPATTO MICRO-S 230V 75Hz</p>			<p>CODICE</p> <p><b>025401</b></p>		
<p>GRUPPO MACCHINA</p> <p><b>TURBO-SMART</b></p>			<p>DISEGNO NUMERO</p> <p><b>CF08-01-00</b></p>		